

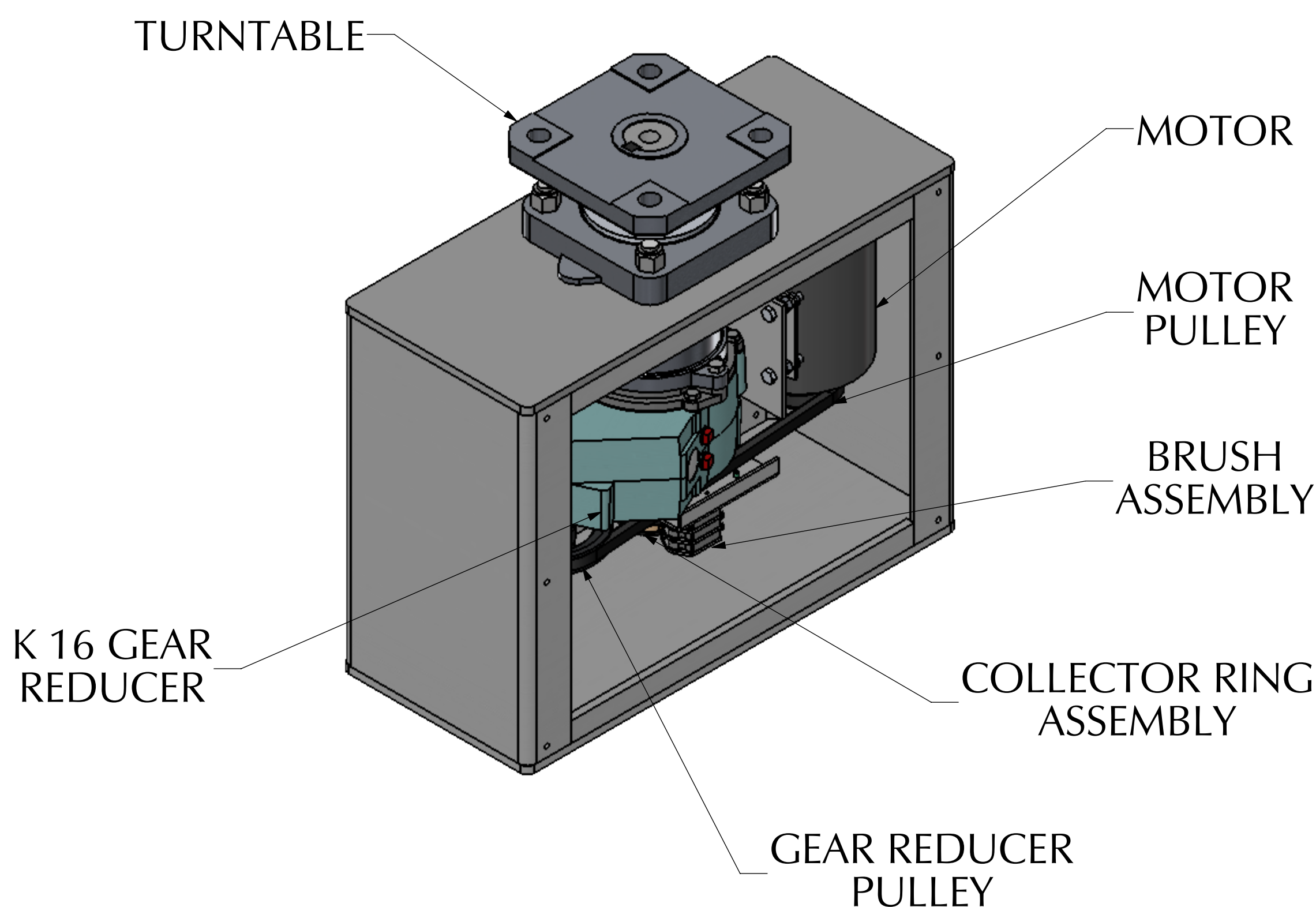

# K-100

Part Number: 135003 361

Hanging Weight Capacity.....3120 lbs [1415 kg]  
 Compressive Weight Capacity.....3120 lbs [1415 kg]  
 Max Display Size.....Contact Dynapac  
 Standard RPM.....6  
 Torque Output @ 6 RPM.....150 ft-lbs [203.4 Nm]  
 Motor Draw.....6A (720 watts)  
 Safety Clutch.....Standard Feature  
 Collector Ring Capacity.....15A at 115 V  
 Shipping Weight.....150 lbs [68 kg]

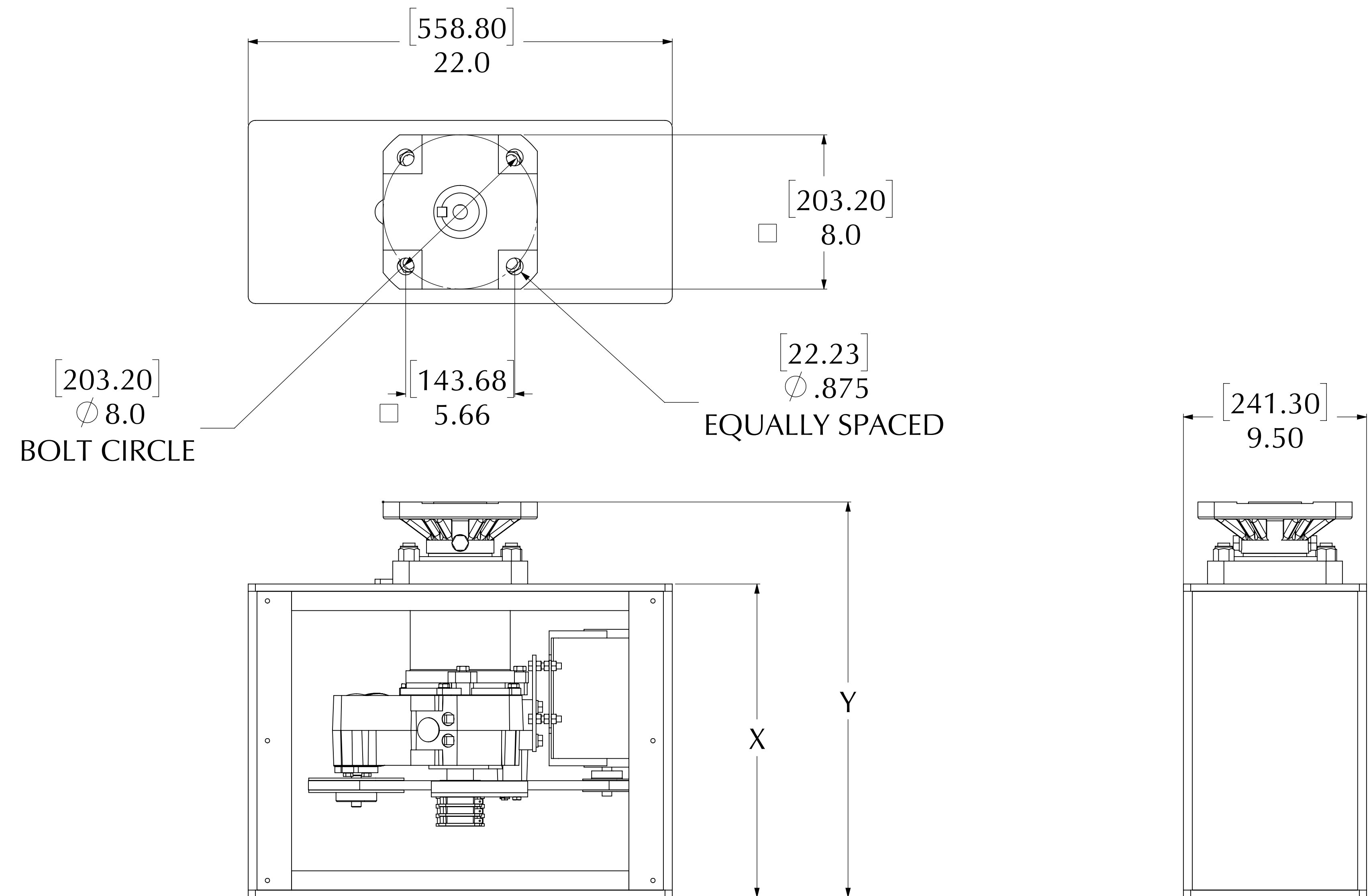

	X	Y
STANDARD FRAME	16.25" [412.75mm]	20.51" [520.85mm]
EXTENDED FRAME	22.25" [565.15mm]	26.51" [673.25mm]

NOTE: MAX COLLECTOR RINGS ON STANDARD UNIT IS 6.

Dynapac Rotating Company Inc.  
 338 Hansen Ave., Salt Lake City, UT 84115  
 Phone: 801-485-2221 • Fax: 801-485-2254  
 email: [info@dynapacrotating.com](mailto:info@dynapacrotating.com) • [www.dynapacrotating.com](http://www.dynapacrotating.com)