



# H-650 HANG Less Collector Ring

Part Number: 153010 021 6W HANG

This indoor hanger unit is ideal for larger diameter (greater than 15') and odd-shape banner signs. The oil-free gear box prevents oil leaks from happening during shipment and storage. Contact a Dynapac technical salesperson for help when selecting this unit.

Hanging Weight Capacity.....500 lbs [226.8 kg]  
 Compressive Weight Capacity.....none  
 Max Display Size.....Contact Dynapac  
 Standard RPM.....2  
 Torque Output @ 2 RPM.....96 in-lbs [10.8 Nm]  
 Motor Draw.....0.2 A (23 watts)  
 Safety Clutch.....Standard Feature  
 Shipping Weight.....38 lbs [17.2 kg]

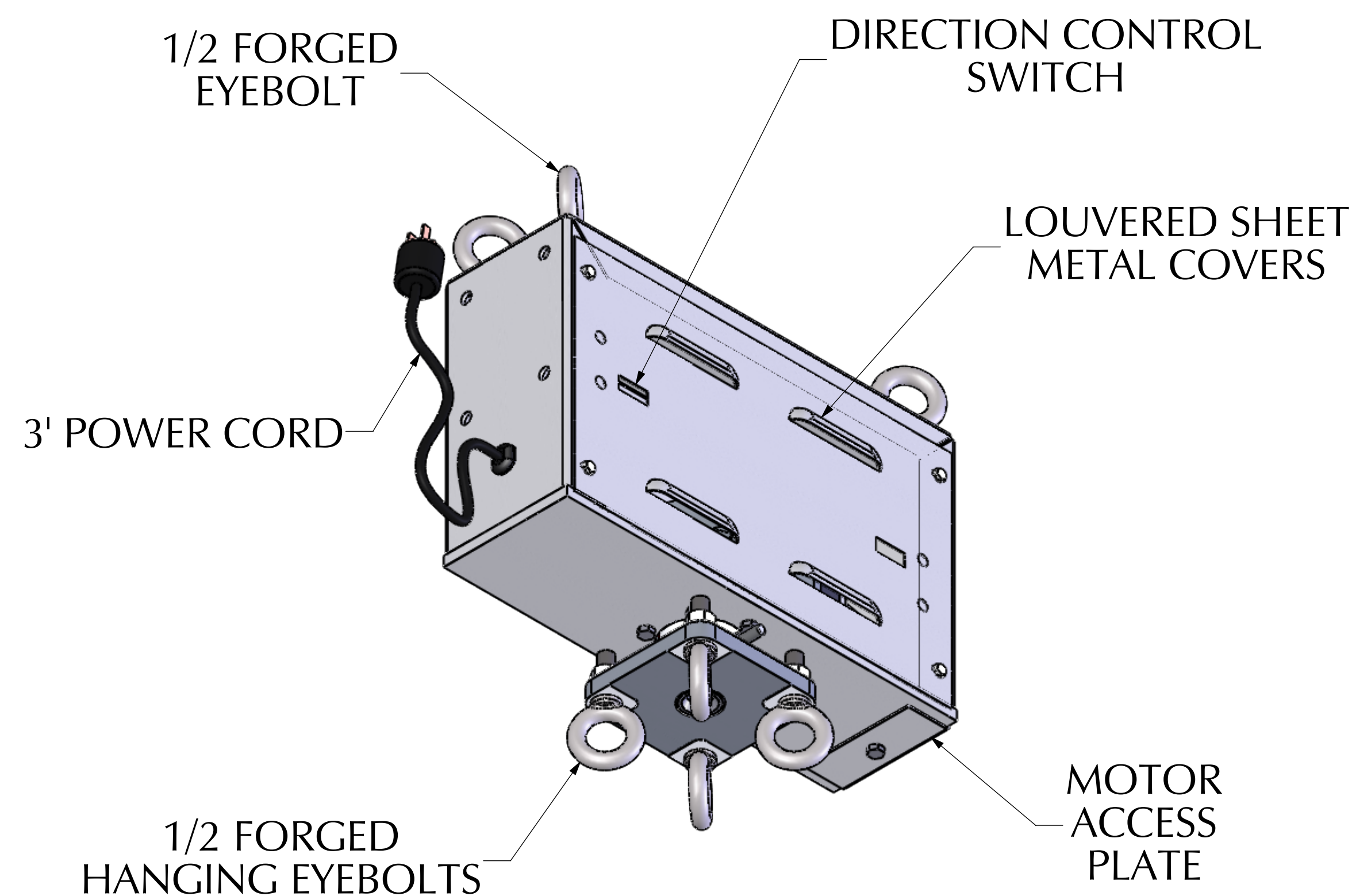
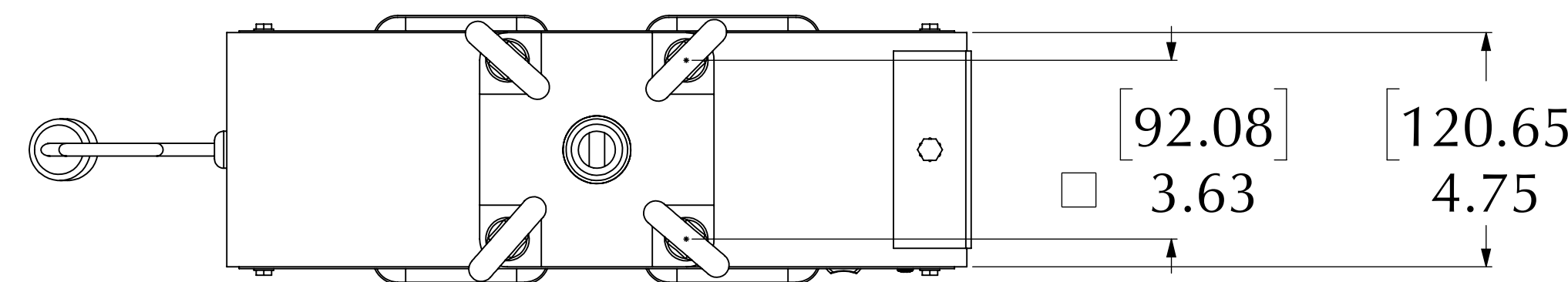
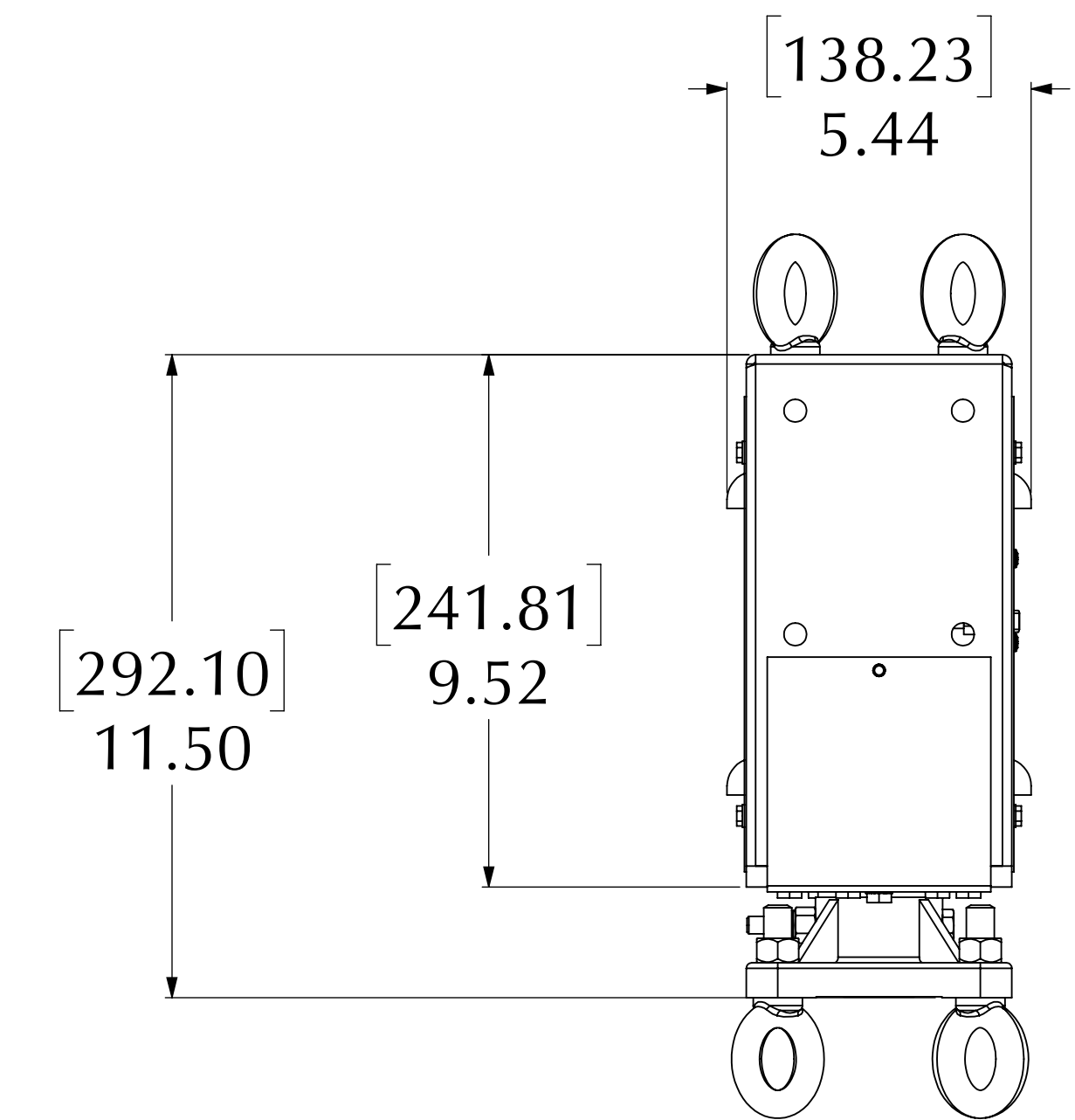
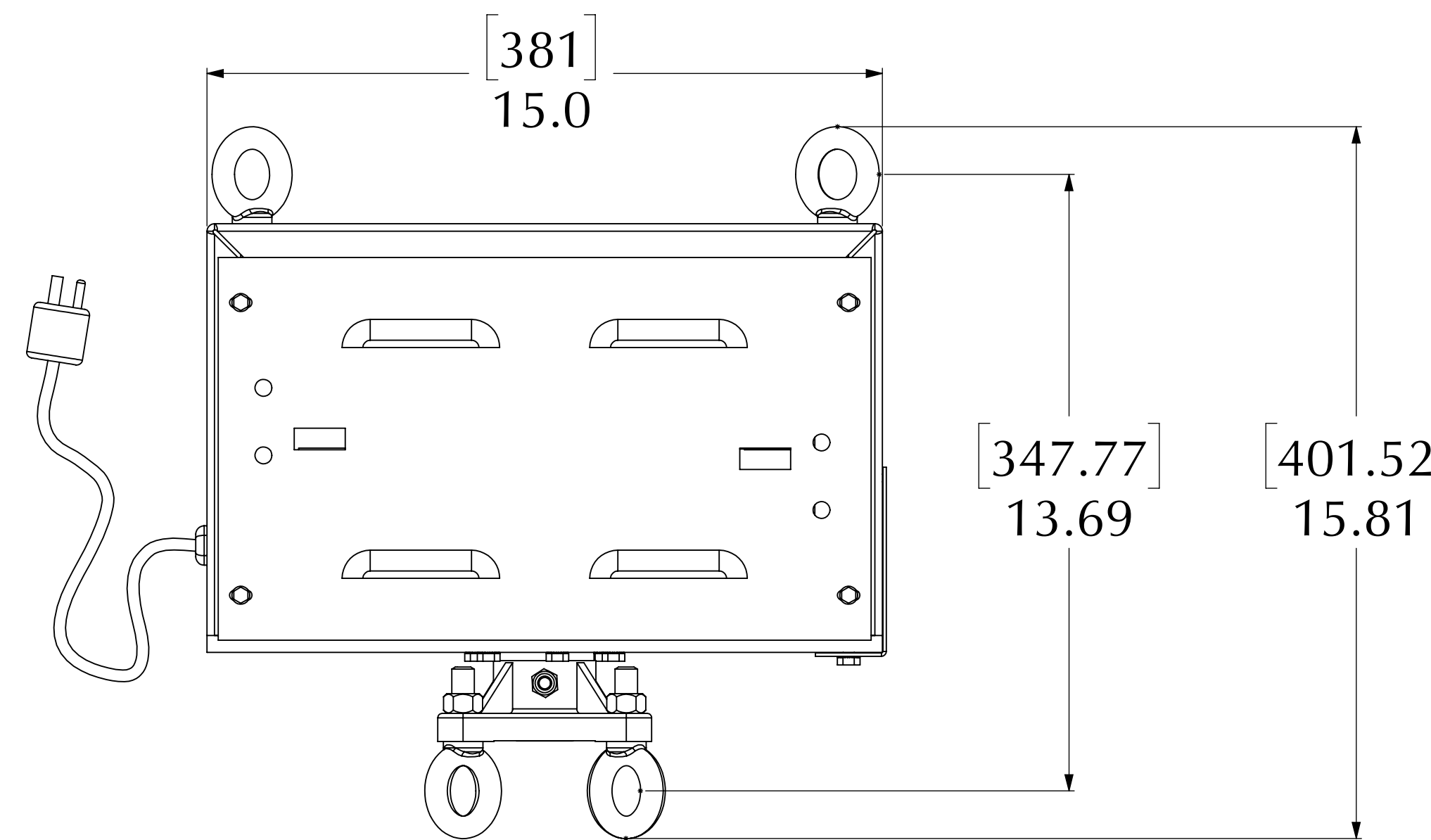
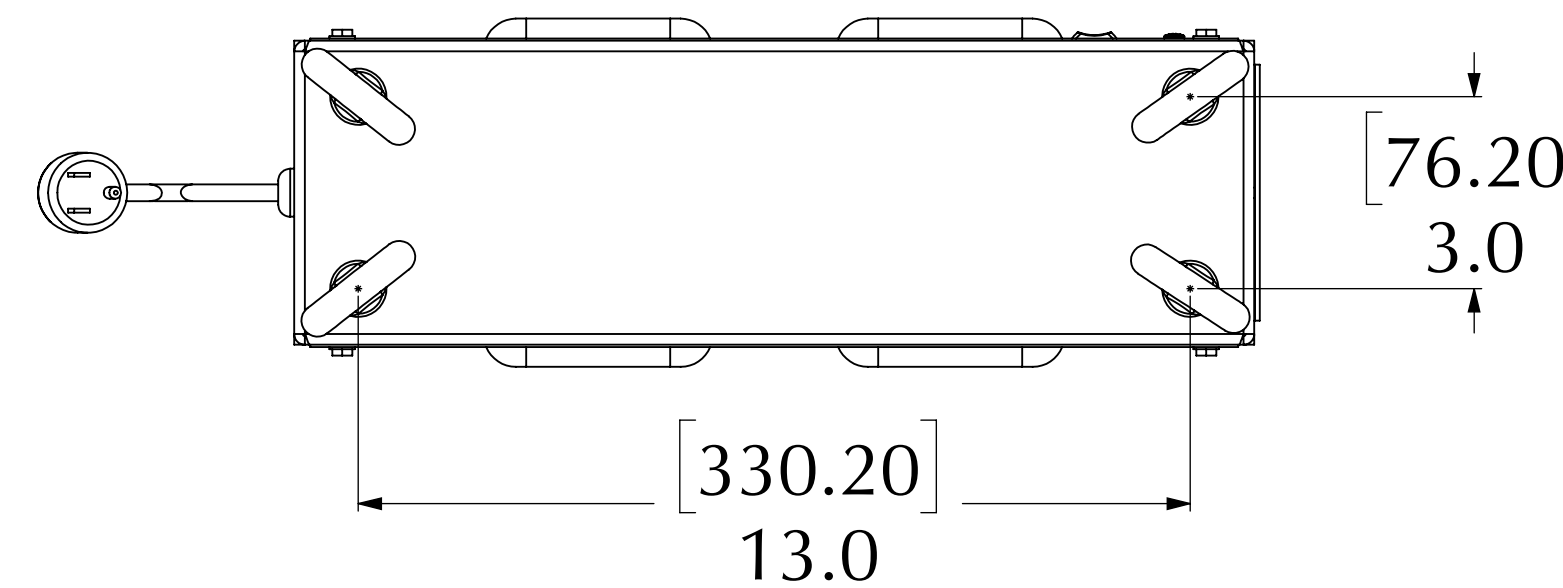

Dynapac Rotating Company Inc.  
 338 Hansen Ave., Salt Lake City, UT 84115  
 Phone: 801-485-2221 • Fax: 801-485-2254  
 email: [info@dynapacrotating.com](mailto:info@dynapacrotating.com) • [www.dynapacrotating.com](http://www.dynapacrotating.com)