

Ø 1.380
(TO FIT OVER
Ø 1.375 SHAFT)

BRUSH ASSEMBLY
33951X (WHERE "X" =
OF BRUSHES)

BRUSH SUPPORT RING
639359

COLLECTOR RING ASSEMBLY
33950X (WHERE "X" = # OF
COLLECTOR RINGS)

COLLECTOR RING COLLAR

SINGLE BRUSH
ASSEMBLY CARTRIDGE
439250

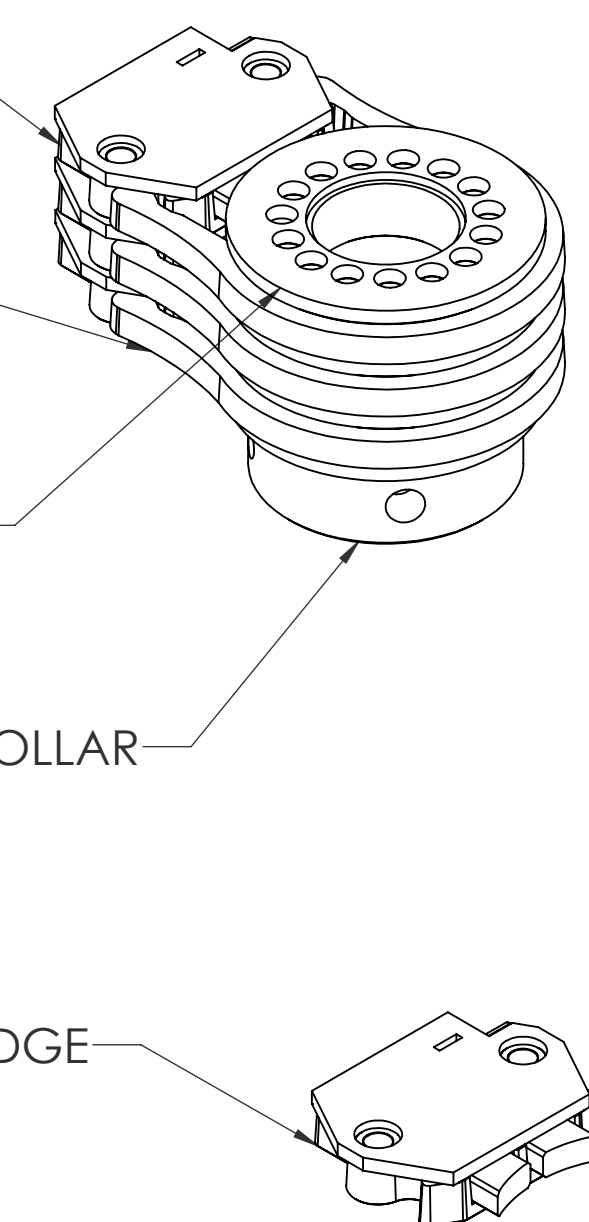

PROPRIETARY AND CONFIDENTIAL
THE INFORMATION CONTAINED IN THIS DRAWING IS THE SOLE PROPERTY OF DYNAPAC ROTATING CO., INC. ANY REPRODUCTION IN PART OR AS A WHOLE WITHOUT THE WRITTEN PERMISSION OF DYNAPAC ROTATING CO., INC. IS PROHIBITED.
© COPYRIGHT DYNAPAC ROTATING CO., INC. ALL RIGHTS RESERVED

UNLESS OTHERWISE SPECIFIED DIMENSIONS ARE IN INCHES TOLERANCES: FRACTIONAL ± 1/32 ANGULAR ± 2° DECIMAL .X ± .125 .XX ± .030 .XXX ± .010	APPROVALS	DATE	DYNAPAC ROTATING CO. SALT LAKE CITY, UTAH 	
	DRAWN ALEX CAMPBELL	6/20/16		
	CHECKED			
MATERIAL	APPLICATION	SIZE	DWG. NO.	REV
FINISH	NEXT ASSY	B	339513 & 339523	
	FINAL ASSY	SCALE: 1:1	SHEET 2 OF 2	